

Instruction Manual

Battery Crimping Tool EZ-300



Due to continuing improvements, actual product may differ slightly from the product described herein.



Read this material before using this product.

Failure to do so can result in serious injury.

SAVE THIS MANUAL

www.fivestar-tools.com

SAVE THIS MANUAL

Keep this manual for the safety warnings and precautions, assembly, operating, inspection, maintenance and cleaning procedures. Write the month and year of purchase. Keep this manual and the receipt in a safe and dry place for future reference.

IMPORTANT SAFETY INFORMATION

In this manual, on the labeling, and all other information provided with this product:



This is the safety alert symbol. It is used to alert you to potential personal injury hazards. Obey all safety messages that follow this symbol to avoid possible injury or death.

▲DANGER

DANGER indicates a hazardous situation which, if not avoided, will result in death or serious injury.

▲WARNING

WARNING indicates a hazardous situation which, if not avoided, could result in death or serious injury.

▲CAUTION

CAUTION, used with the safety alert symbol, indicates a hazardous situation which, if not avoided, could result in minor or moderate injury.

GENERAL SAFETY RULES

TO WORK IN SAFE CONDITIONS WITH THIS TOOLING, IT IS IMPERATIVE TO READ CAREFULLY THE DIRECTIONS FOR USE AND TO FOLLOW THE INSTRUCTIONS IT CONTAINS. IF YOU DO NOT RESPECT THE INFORMATION WRITTEN IN THAT INSTRUCTION MANUAL THE WARRANTY WILL BE CANCELLED.

1. Work area safety

- a. Keep work area clean and clear. Cluttered or dark areas invite accidents.
- b. This tool is not insulated; please do not use it on live conductor.
- c. Please do not use or store the tool under high temperature, or one surrounding filling with corrosive fluid. Pay attention to the sealing kits becoming aging.
- d. Keep children and bystander away while operating the hydraulic crimping tool. Distractions will cause you to lose control.

2. Electrical safety

- e. Make sure the plug matches with the plug seat. Never try any changes on the plug.
- f. Do not put tool, battery and charger under a rainy or humid surroundings, it is easy to trigger an electric shock accident if any water goes into the electric system of the tool.
- g. Do not use electric wire to carry, pull, or to draw out the plug. The damaged or twined wire may cause an electric shock accident.
- h. If the charger was strongly crashed, or dropping down or any other damages happening, please do not try to repair it by yourself, send it back to the authorized service center as soon as possible. The damaged charger may cause an electric shock accident.

- i. The best temperature for charging is between 10°C-40°C. Make sure the air hole of the battery and charger are uncovered during charging.
- j. Please pull out the plug when meet a bad weather.
- k. Please do not burn the battery or make it being short-circuited, it may cause explosion.
- l. Keep the tool out of reach of children and other person who are not familiar with it.

3. Personal safety

- m. Stay alert, watch what you are doing and use common sense when operating the tool. Do not use the tool while you are tired or still under the influence of drugs, alcohol or medication. A moment of inattention may result in series personal injury.
- n. Use safety equipment. Always use safety equipment such as mask, helmet, safety cap, insulating shoes and etc to reduce the risk of personal injury.
- o. Dress properly. Do not wear loose clothing or jewelry. Keep your hair, clothing and gloves away from moving parts. Loose clothes jewelry or long hair can be caught in moving parts.
- p. Maintain power tools. Check for misalignment or binding of moving parts, breakage of parts and any other condition that may affect the tool operation. If damaged, have the tool repaired before use. Many accidents are caused by poorly maintained power tools.
- q. Please use the tool properly, the tool with correct power will do the job better and safer at the rate for which it was designed.
- r. Do not put your fingers into the head of the tool during operating. Your fingers could be pinched very severely.

UNDERSTAND YOUR TOOL

EZ-300 is a tool for crimping Cu/Al lugs with cables from 16-300 mm². It is powered by Li-ion, actuated by motor and controlled by MCU. With a high pressure hydraulic system, it is a perfect tool to be used in electrical construction site.

1. Specification

Max. crimping force:	60KN
Crimping range:	CU 300mm ² /AL 240mm ²
Stroke:	17mm
Hydraulic oil:	Shell Tellus T15#
Ambient temperature	-10-40°C
Voltage:	18V
Time/crimp:	3-6s(depend on the size of cable)
Time/charger:	Approx. 310 times (CU 150mm ²)
Charging voltage:	AC 100V~240V ;50~60Hz
Charging time:	Approx.2 hours
Accessories:	
Crimping die:	16.25.35.50.70.95.120.150.185.240.300 mm ²
Battery:	2 pcs
Charger:	1 pc
Sealing ring of cylinder:	1 set
Sealing ring of safety valve.	1 set

2. Description of components:

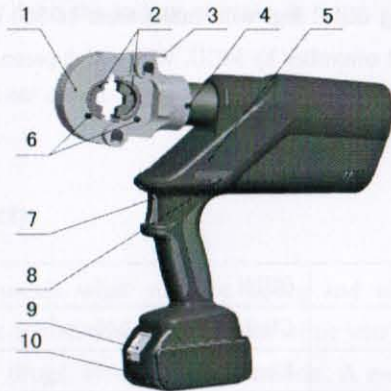

Parts No.	Description	Function
1	Die holder	For fixing die
2	Die	For crimping, interchangeable die
3	Latch	For locking /unlocking the crimping head
4	Limited screw	For prevent head from dropping or popping
5	LED indicator	For indicating the operating condition and battery discharging situation.
6	Retaining clips	For locking/unlocking die.
7	Trigger	For starting operation
8	Retract button	For manual retracting the piston in case of an incorrect operation.
9	Battery lock	For locking/unlocking the battery.
10	Battery	For supplying power, rechargeable Li-ion (18V) .

3. Function description

MCU

MCU –automatically detect the pressure during operation and provide security protect, shut off the motor and reset automatically after operation.

AUTO

Auto reset- Release the pressure automatically, retract the piston to the starting position when reached the max output.

MAN

Manual reset —Can retract the piston to the starting positioning in case of an incorrect operation.



The unit is equipped with a double piston pump which is characterized by a rapid approach of the die towards the connector and a slow crimping motion..



The head can be smoothly turned by 360°around the longitudinal axis in order to gain better access to tight corners and other difficult working areas.



One significant sound will be heard and a red display flashes if any error occurs.



The whole tool is controlled by one trigger. This results in an easy handling and a better grip compared to a two button operation.





Li-ion batteries do neither have a memory effect nor self discharge.

Even after long periods of non operation the tool is always ready to operate. In addition we see a lower power weight ration with 50% more capacity and shorter charging cycles compare to NIMH batteries..



A temperature sensor makes the tool stop working automatically when the temperature over 60°C under long time working, the fault signal sounds, it means the toll can't continue work until the temperature reduce to the normal.

Series No			Instruction	What it means
1	★ ★		Self-checking	Self-checking to assure everything is ok
2	★—5sec		Overload	Hydraulic system may damaged and need check immediately
3	★ ★ ★	● ● ●	Charging signal	Lacking power and need charging.
4	★—5sec	●—5sec	Power lacking warning	No power and need charging immediately
5	★ ★ ★ ★	● ● ● ●	Temperature warning	Temperature too high and need to cool down.
6	★ ★ ★ ★ ★	● ● ● ● ●	No pressure	Motor working but without pressure

OPERATING INSTRUCTION

Please check carefully before operating. Make sure the tool is complete and has no damage part.

1. Charging

Push battery into charger and connect the plug with the plug seat. Make sure the room temperature is between 10°C-40°C. The charging time is around 2 hours. Please see the illustration below.



1.



2.

The detail of the charging information, please refer the manual (MANUAL FOR CHARGER)

⚠CAUTION

The battery can be used for hundreds of times, when the life span reduced obviously, change to a new battery please.

Please charging the battery in time to avoid it to be used up absolutely; otherwise it will become useless forever. if the battery not be used for a long time, it will discharge automatically. Make sure to charge it one time per/each quarter.

2. Usage of the tool

- 1) First you have to check the LED indicator is light or not. If the indicator is light on for more than 5 seconds, it means no power of the battery and should change the full powered battery to settle on the tool.
- 2) Select the right dies for the intended application,

⚠CAUTION Don't operate the tool without dies.

the crimping head has to be opened by pushing the Latch, place two dies up and down after activating the retaining clips. Then the connecting material shall be positioned in the crimping head correctly, in order to start the crimping procedure,

- 3) A crimping process is initiated by switching the trigger. It is defined by the closing motion of the dies. The connection material is positioned in the stationary half of the crimping dies and the moving part is approaching the compression point.
- 4) A crimping cycle is terminated when the dies contacted each other and when the maximum crimping force is reached. After the crimping cycle is completed the piston retracts automatically. Afterwards a new crimping cycle can be initiated or the crimping process can be terminated by opening the latch and remove the connecting material out of the head.

⚠CAUTION

The crimping process can be interrupted at any moment by releasing the trigger.

⚠DANGER

Do not put your fingers into the head of the tool during operating. Your fingers could be pinched very severely.



3.

4.

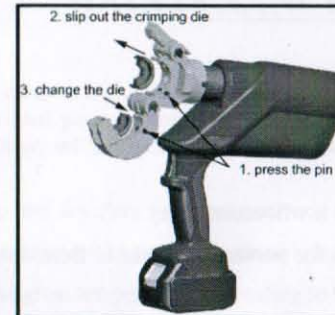

5.

6.

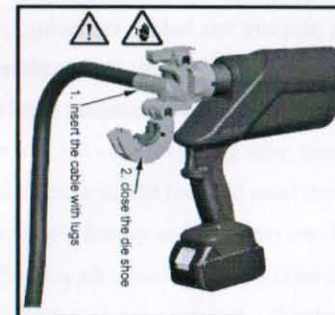

7.

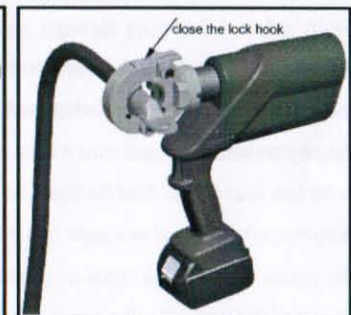

8.



9.



10.

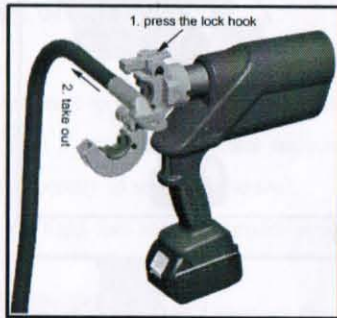

11.

⚠WARNING

1. Do not knock any parts of the tool, otherwise it will cause injury.
2. The design of the limit screw on the head is for preventing the head from dropping or popping.
3. Make sure the head was locked firmly during operation.
4. The built-in safety valve goes through strict pressure test before marketing, please do not adjust the pressure by unprofessional person. If the pressure is not enough please return the tools back to the service center. The tool only can be reused after checking and testing by trained person.

Standard hexagonal die size: 16.25.35.50.70.95.120.150.185.240.300 mm²



If ask for special size or special shape, please contact the distributor or manufacturer, they can make die according to detail requirements.

⚠CAUTION

Please select the correct die according to the AL/Cu terminal which to be crimped, to choose the wrong die may cause loose crimping result or generate a lot of burs.

MAINTENANCE AND SERVICING

The tool earns a high precise design, please use it properly and do not disassemble it by unprofessional person, otherwise we will not responsible for the problems cause by above misuse. Or we will carry out repair if the users are willing to pay for the spare parts cost.

1. Keep tool dry. Any water may corrode the tool surface, metal or electric parts. If contact water, take out battery and assembly it back when the tool is fully dry.
2. Avoid great temperature fluctuating to the tool. Otherwise it will cause the plastic housing to be deformed, shorten the life span of the electric parts and damage the battery.
3. Please do not use any chemical agent to wash the tool.
4. In order to prolong the life span, please change the hydraulic oil per year.
5. If the tool not used for a long time, please make sure the piston stay on its starting position, clear up the tool and paint the rustproof oil both to the tool and accessories. Take out the battery and put them into box and store the tool in a dry surrounding.
6. The Sealing kit inside the tool will be abraded in some degree after using, when the oil leaking a lot, please contact the distributor to replace the Sealing kit in timely.

PLEASE READ THE FOLLOWING CAREFULLY

THE MANUFACTURER AND/OR DISTRIBUTOR HAS PROVIDED THE PARTS LIST AND ASSEMBLY DIAGRAM IN THIS MANUAL AS A REFERENCE TOOL ONLY. NEITHER THE MANUFACTURER NOR DISTRIBUTOR MAKES ANY REPRESENTATION OR WARRANTY OF ANY KIND TO THE BUYER THAT HE OR SHE IS QUALIFIED TO MAKE ANY REPAIRS TO THE PRODUCT, OR THAT HE OR SHE IS QUALIFIED TO REPLACE ANY PARTS OF THE PRODUCT. IN FACT, THE MANUFACTURER AND/OR DISTRIBUTOR EXPRESSLY STATES THAT ALL REPAIRS AND PARTS REPLACEMENTS SHOULD BE UNDERTAKEN BY CERTIFIED AND LICENSED TECHNICIANS, AND NOT BY THE BUYER. THE BUYER ASSUMES ALL RISK AND LIABILITY ARISING OUT OF HIS OR HER REPAIRS TO THE ORIGINAL PRODUCT OR REPLACEMENT PARTS THERETO, OR ARISING OUT OF HIS OR HER INSTRALLATION OF REPLACEMENT PARTS THERETO.

LIMITED 1 YEAR WARRANTY

We make every effort to assure that its products meet high quality and durability standards, and warrants to the original purchaser that this product is free from defects in materials and workmanship for the period of one year from the date of purchase(90 days if used by a professional contractor or if used as rental equipment). This warranty does not apply to damage due directly or indirectly, to misuse, abuse, negligence or accidents, repairs or alterations outside our facilities, normal wear and tear, or to lack of maintenance. We shall in no event be liable for death, injuries to persons or property, or for incidental, contingent, special or consequential damages arising from the use of our product. Some states do not allow the exclusion or limitation of incidental or consequential damages, so the above limitation of exclusion may not apply to you. THIS WARRANTY IS EXPRESSLY IN LIEU OF ALL OTHER WARRANTIES, EXPRESS OR IMPLIED, INCLUDING THE WARRANTIES OF MERCHANTABILITY AND FITNESS.

To take advantage of this warranty, the product or part must be returned to us with transportation charges prepaid. Proof of purchase date and an explanation of the complaint must accompany the merchandise. If our inspection verifies the defect, we will either repair or replace the product at our election or we may elect to refund the purchase price if we cannot readily and quickly provide you with a replacement. We will return repaired products at our expense, but if we determine there is no defect, or that the defect resulted from causes not within the scope of our warranty, then you must bear the cost of returning the product.

The warranty gives you specific legal rights and you may also have other rights which vary from state to state.