

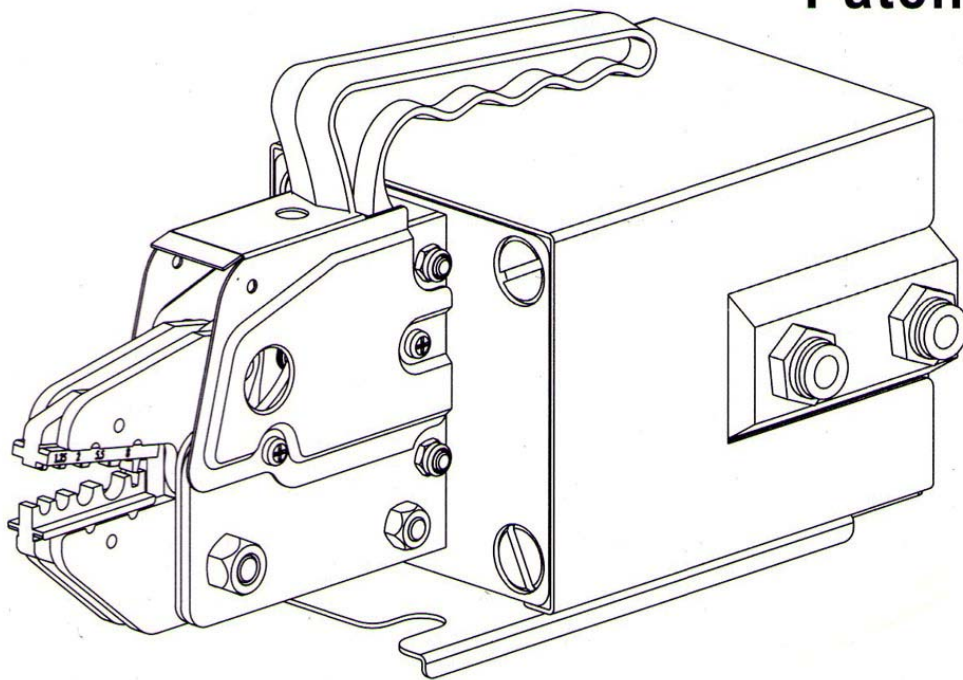

OPERATION MANUAL

AM-10 PNEUMATIC (TERMINAL) CRIMPING TOOL

Patent



www.fivestar-tools.com

Product Instruction

About product:

The machine is driven by dual-action normal cylinder, which has advantages of high efficiency and quality in crimping force and speed. The machine is fit for crimping many kinds of terminals. The die sets are interchangeable with our manual crimping tools. So we can provide you all kinds of die sets for crimping.

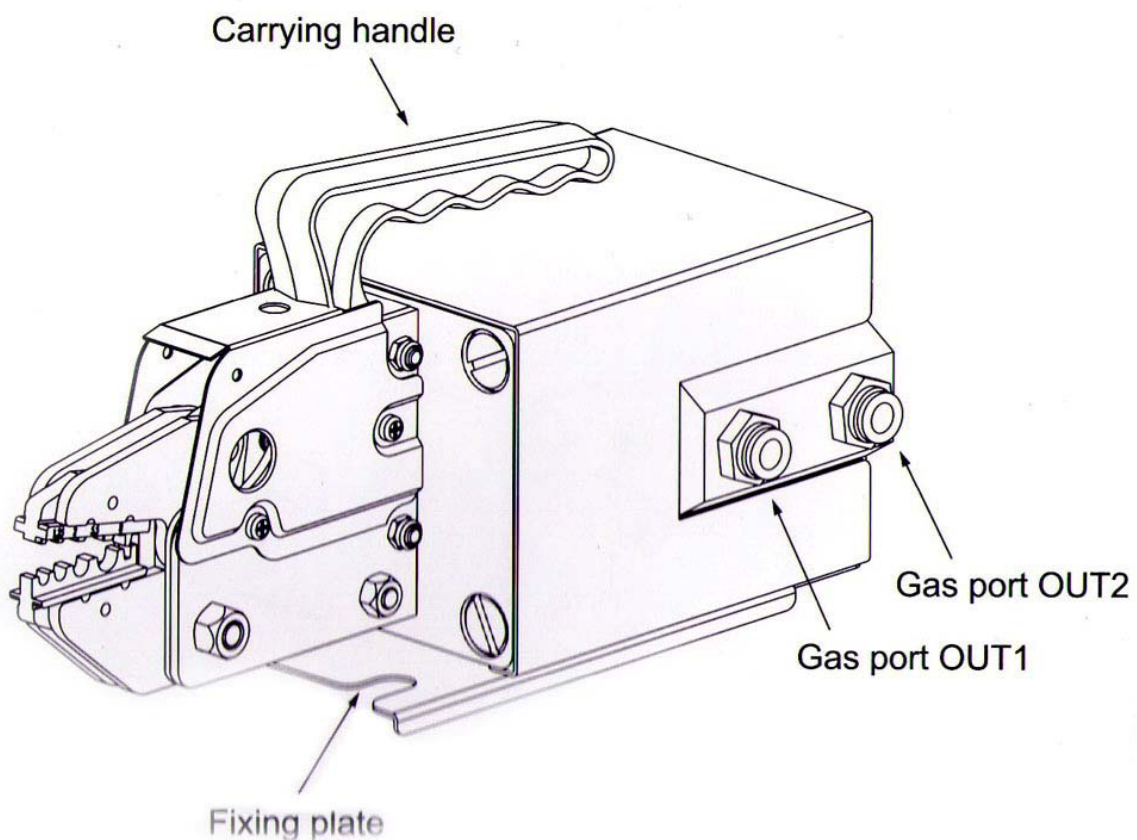

-Maintenance and storage:

- 1、Lubricate all mechanical moving joint before operation to increase their service life.
- 2、 Since the product is pneumatic device, do not operate or store it in environment with high or low temperature and high humidity.
- 3、 Please keep it clean and dry before storage to avoid rusting. Mount dust caps at the gas inlet and outlet or adopt other measures.

-Replace clamps:

- 1、 Cut off gas supply.
- 2、 Dismount the fix bolts on the clamp with the L spanner.
- 3、 Replace a desired clamp and screw down the bolt again.

-Notice for assembly of clamps:

- 1、 Since the clamps are used in pairs, please align them well.
- 2、 After assembly, press the foot operated gas valve slowly to make the machine worked at low speed in order to check the mounted die sets.

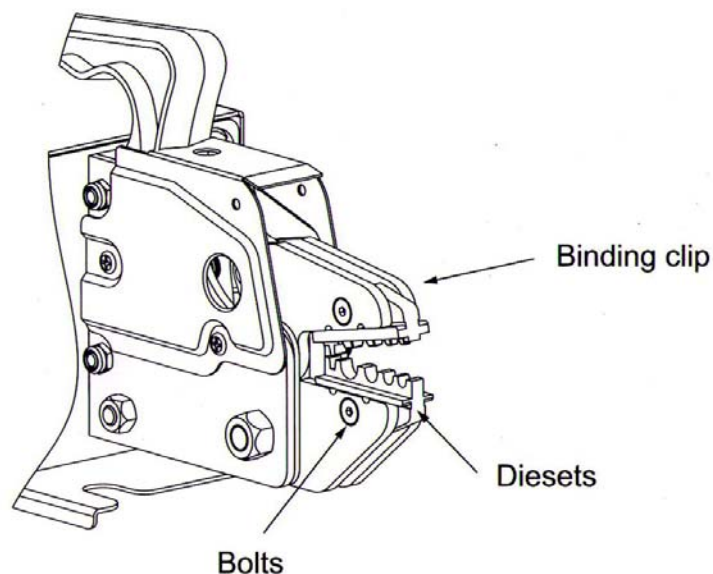

Before operation, please read the instruction carefully for operating method and technical parameters.

-Operating method:

- 1、 Connect the gas hose according to relative marks on the equipment and accessories.
- 2、 Open gas supply, the binding clip should be opened for [crimping](#). Place the terminal in a relative clamp, press the gas valve by the foot, and release it after finished.
- 3、 Crimping speed can be controlled by the foot or optional pipe joint with a throttle valve.
- 4、 When processing terminals with large size, please guarantee enough gas supply and air pressure.

-Operating condition and notice:

- 1、 Flow in the equipment: Compressed air.
- 2、 Operating condition and flow temperature: 5~60°C
- 3、 Medium in the cylinder should be filtrated by filter element above 40um before injection (Viz. gas supply to the cylinder should pass the air filter before operation)
- 4、 Clean all gas hoses and fittings for connecting the pipe line to protect the cylinder.
- 5、 If used in low temperature, take some measures to avoid freezing in the system.
- 6、 Advice: Medium in the [cylinder](#) should be lubricated before operation (Viz. add an atomized lubricator in the gas supply line; turbine 1#oil ISOVG32) is recommended.

-Technical parameters:

Description	AM-10
Output force	1.3T Air Pressure 0.5Mpa
Applicable air pressure	0.5~0.7Mpa
Max operation pressure	1.0Mpa
Max crimping capacity	Insulated terminal 16mm ²
External dimension	266mm*142mm*117mm
Weight	3.5Kg

-Confirm accessories before operation:

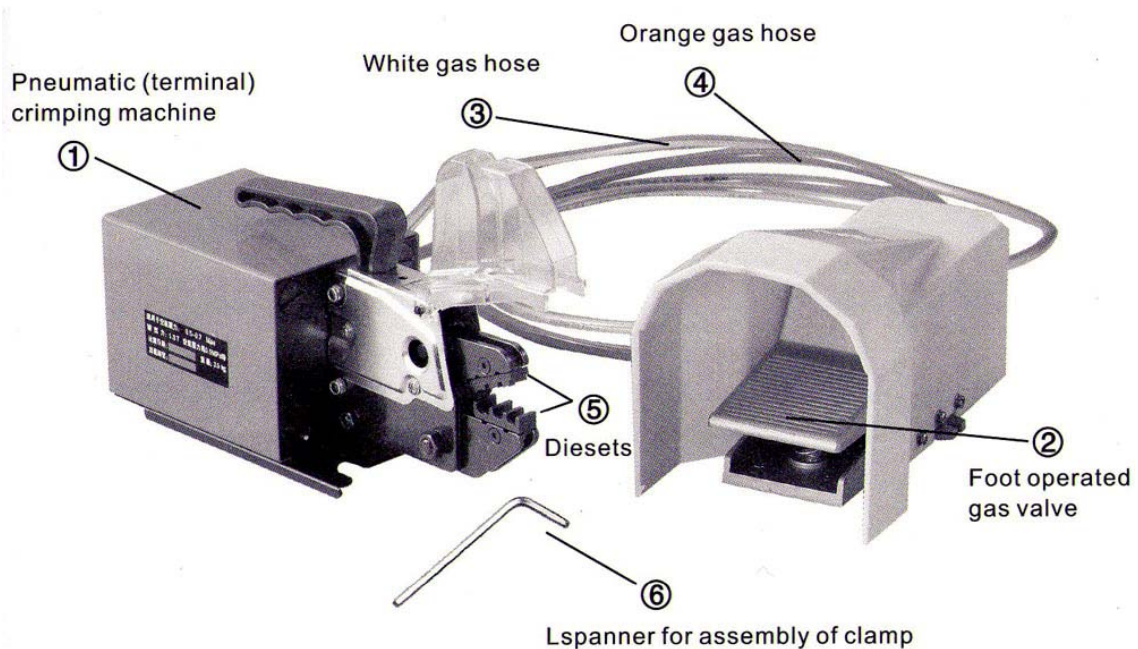

A02H

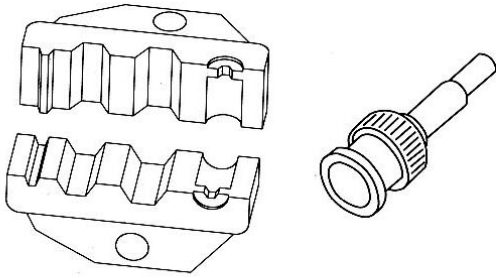

8.0mm²/6.4mm²/1.7mm²/1.0mm²

A02H1

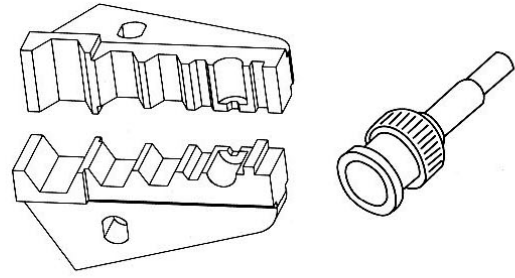

8.8mm²/8.1mm²/6.5mm²

A02H3

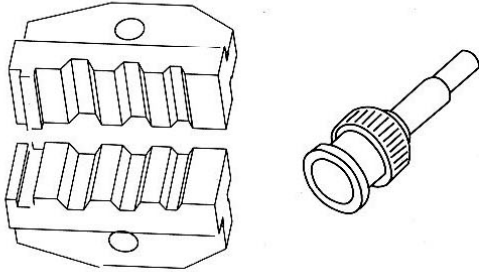

6.5mm²/5.4mm²/1.7mm²

A05H

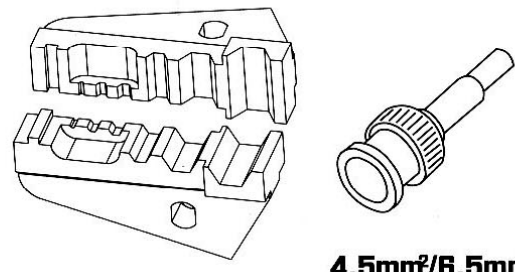

4.5mm²/6.5mm²
7.0mm²/1.7mm²/1.0mm²

A457

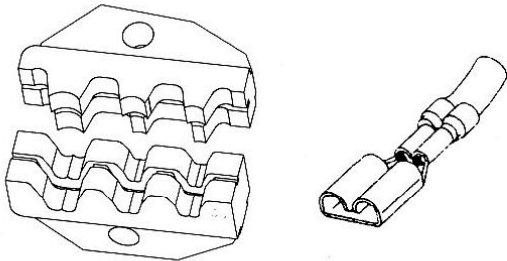

1.0-4.0mm²

A1016

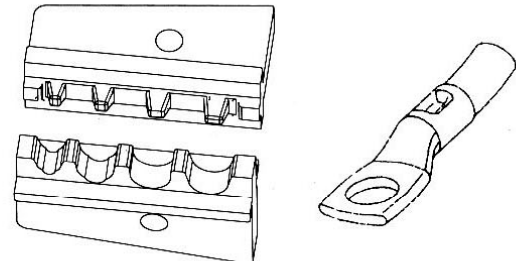

0.5-16mm²

A10

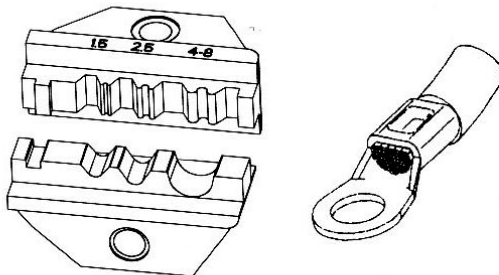

1.5-6mm²

A101

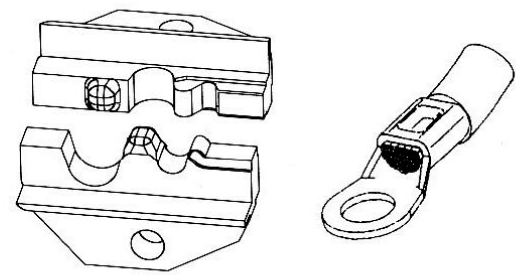

0.5-10mm²

A04WFL

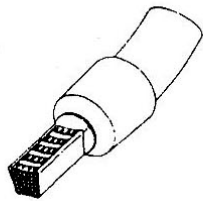
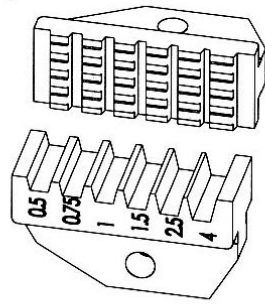

0.5-4mm²

A35WF

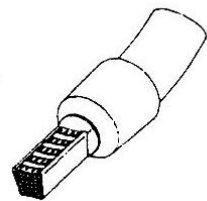
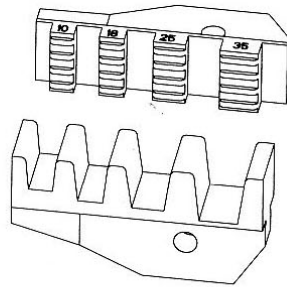

10-35mm²

A26TW

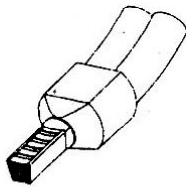
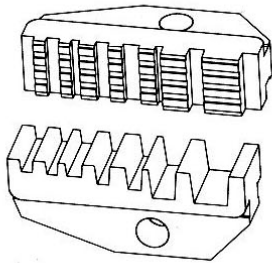

2.5-6.0mm²

A04WF

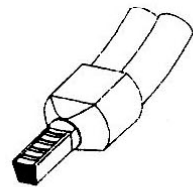
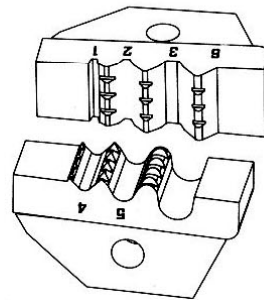

1.0-6mm²

A03C

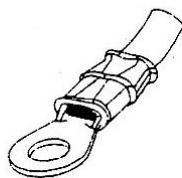
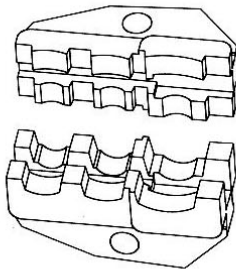

0.75-6mm²

A30J

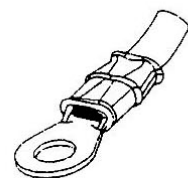
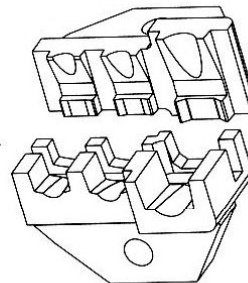

0.75-6mm²

A05FL

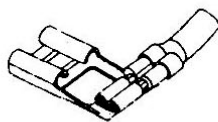
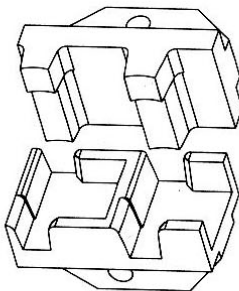

4.8-6.3mm²

A07FL

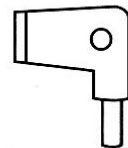
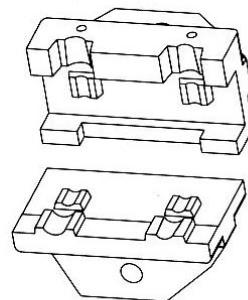

1.25-2.5mm²